

### LynxGate®: Switch Gateway Processing

What If You Could Increase Revenue, Reduce Costs, and Strengthen Member Relationships Through a Cost-effective Solution That Gives You Realtime Access to Switches and Networks?



LynxGate: Switch Gateway Processing from Fiserv gives you realtime access to any switch or network. Its Web-based user interface and fully integrated relational database create a solution that's simple to use, yet capable of supporting advanced features like member customization, automated balancing, and device control.

One of the main features of ATM, debit, and credit cards is the ability of cardholders to access their funds at ATMs and merchant terminals throughout the world. Switches and networks make this possible.

#### Switches and Networks

LynxGate provides access to all major switches for authorization of network transactions. Your credit union determines which switch to use and under what circumstances. You can choose to route all transactions through one switch or you can use different switch processors for BIN, acquiring terminal, or other factors. You can also designate alternate switches to be used when the primary switch is unavailable.

LynxGate inventories you can customize at the switch level include deposit hold days, deposit limits, and fee plans. The LynxGate inventories you can customize at the BIN

level include deposit hold days, deposit limits, fee plans, operation restrictions, promotional messages, and velocity limits.

#### Fees

Fee plans may be defined to assess transaction fees based upon a variety of criteria including transaction counts within type, originating network and terminal. This allows the financial institution to define free transaction counts by type, network and terminal and to customize fee plans at the BIN or cardholder level.

Surcharge fee plans may also be defined to assess fees for foreign transactions performed at financial institution terminals. Surcharge fee plans may be customized at the terminal level or by BIN. Lists of BINs for which surcharge fees are to be waived or discounted may be maintained.

#### Switch Gateway Processing Highlights

- Generates revenue from foreign transactions at credit union ATMs
- Eliminates network charges by intercepting on-us transactions
- Minimizes your investment by using cost-effective hardware
- Increases ATM and network availability and uptime
- Streamlines balancing functions through automated online tools
- Maximizes member relationships by customizing products and services



Fiserv is driving innovation in Payments, Processing Services, Risk & Compliance, Customer & Channel Management and Insights & Optimization, and leading the transformation of financial services technology to help our clients change the way financial services are delivered. Visit [www.fiserv.com](http://www.fiserv.com) for a look at what's next, right now.

## Key Features

- Automated balancing with access to transaction detail and exception subsystem
- Member relationship management through additional velocity limits, promotional messages on screen and receipt, fee plans at the cardholder or BIN level
- Guest customization including selective surcharge support, routing by BIN and alternate switch assignments
- Expanded device support and monitoring
- Data change auditing and advanced encryption functions

## Monitoring Advantages

- Monitors an unlimited number of switch connections
- Maintains constant communication with your system and remote personnel
- Minimizes evening and weekend downtime

- Provides reliable, unattended operation
- Provides alerts by e-mail, text messaging, SNMP, voice and paging
- Sends alerts based on activity (such as number of bad PINs during a specified amount of time)
- Allows you to designate who receives the initial notification and contacts for escalation
- Reports uptime usage statistics to track reliability and trends over time
- Strengthens control of network operations
- Maximizes the performance of your network
- Enhances member service levels

## Connect With Us

For more information on solutions from Fiserv, please contact us at 800-872-7882 or visit [www.fiserv.com](http://www.fiserv.com).

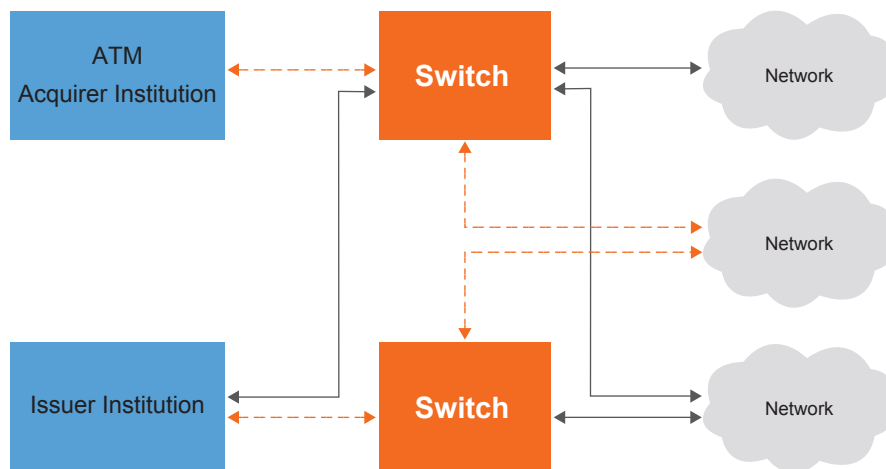

**Fiserv, Inc.**  
255 Fiserv Drive  
Brookfield, WI 53045

800-872-7882  
262-879-5322  
[getsolutions@fiserv.com](mailto:getsolutions@fiserv.com)  
[www.fiserv.com](http://www.fiserv.com)